

REV	DESCRIPTION	DRAWN	DATE
		APPROVED	DATE

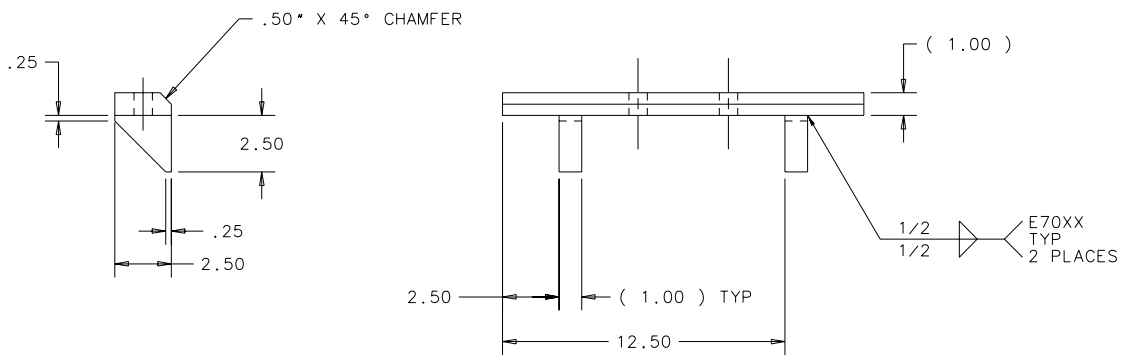
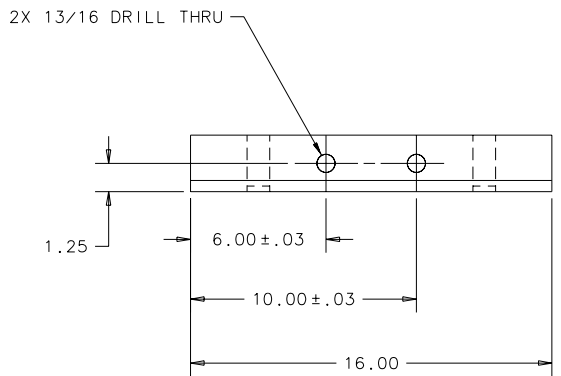

ITEM	PART NO.	DESCRIPTION OR SIZE	QTY.
2	COML	A36 CARBON STEEL 1" THICK	1
1	COML	A36 CARBON STEEL 1" THICK	1

PARTS LIST			
UNLESS OTHERWISE SPECIFIED	ORIGINATOR		
.XX	.XXX	ANGLES	
± .06	± ---	± ---	
1. BREAK ALL SHARP EDGES .015 MAX.	APPROVED	I. FANG	
2. DO NOT SCALE DRAWING.	USED ON	ME-421008	
3. DIMENSIONS BASED UPON ANSI Y14.5M-1982	MATERIAL	SEE PARTS LIST ABOVE	
4. ALL DIMENSIONS ARE INCHES			
5. MAX. ALL MACH. SURFACES 250			

**FERMI NATIONAL ACCELERATOR LABORATORY**  
UNITED STATES DEPARTMENT OF ENERGY

PPD/MECHANICAL DEPARTMENT  
E907 CKOV/CHAMBER #2 STAND  
SUPPORT CART ANGLE MOUNT BRKT

SCALE 1:4	DRAWING NUMBER 3907.500-MC-421013	SHEET 1 OF 1	REV
CREATED WITH : Ideas8m4		GROUP: PPD/MECHANICAL DEPARTMENT	